

TOCON_ABC2

Broadband SiC based UV photodetector with integrated amplifier

GENERAL FEATURES

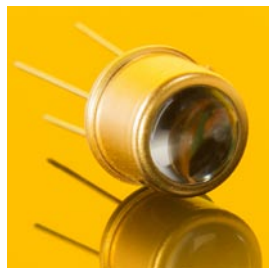

Properties of the TOCON_ABC2

- Broadband SiC based UV photodetector in TO5 housing with concentrator lens cap
- 0...5 V voltage output, also available with 4..20mA current loop
- peak wavelength at 280 nm
- max. radiation (saturation limit) at peak is 180 nW/cm²,
minimum radiation (resolution limit) is 18 pW/cm²
- Applications: low UV radiation, occupational safety

What is a TOCON?

A TOCON is a UV photodetector with integrated amplifier converting UV radiation into a voltage. The V_{out} pin of the TOCON can be directly connected to a controller, a voltmeter or any other data analyzing device with voltage input. Modern electronic components and a hermetically sealed metal housing with UV glass window eliminate noise caused by parasitic paths inside the package and EMI. A TOCON is a perfect solution for each industrial UV sensing application starting from flame or fire detection at pW/cm² level up to UV curing lamp control at W/cm² level. This thirteen orders of magnitude measurement range is covered by ten different TOCONs that differ by their sensitivity. The TOCONs are produced as UV broadband sensors or with filters for selective measurement.

Silicon Carbide (SiC) detector chip inside

Sophisticated electronics and the sglux in-house produced SiC detector chip featuring a PTB-reported extreme radiation hardness make a TOCON a reliable component in harsh environments as well as for extremely low or extremely high UV radiation.

NOMENCLATURE

TOCON_	ABC, A, B, C, blue or GaP	1 ... 10
	Spectral response	Irradiance limits ($V_{supply}=5V, \lambda = \lambda_{max}$)
	ABC = broadband $\lambda_{max} = 290 \text{ nm}$ $\lambda_{S10\%} = 227 \text{ nm} \dots 360 \text{ nm}$	1 = 1,8 pW/cm ² ... 18 nW/cm ²
	A = UVA $\lambda_{max} = 331 \text{ nm}$ $\lambda_{S10\%} = 309 \text{ nm} \dots 367 \text{ nm}$	2 = 18 pW/cm ² ... 180 nW/cm ²
	B = UVB $\lambda_{max} = 280 \text{ nm}$ $\lambda_{S10\%} = 243 \text{ nm} \dots 303 \text{ nm}$	3 = 180 pW/cm ² ... 1,8 μW/cm ²
	C = UVC $\lambda_{max} = 275 \text{ nm}$ $\lambda_{S10\%} = 225 \text{ nm} \dots 287 \text{ nm}$	4 = 1,8 nW/cm ² ... 18 μW/cm ²
	Blue = blue light $\lambda_{max} = 445 \text{ nm}$ $\lambda_{S10\%} = 390 \text{ nm} \dots 515 \text{ nm}$	5 = 18 nW/cm ² ... 180 μW/cm ²
	GaP = UV + VIS $\lambda_{max} = 445 \text{ nm}$ $\lambda_{S10\%} = 190 \text{ nm} \dots 570 \text{ nm}$	6 = 180 nW/cm ² ... 1,8 mW/cm ²
	E = UV-Index spectral response according to ISO 17166	7 = 1,8 μW/cm ² ... 18 mW/cm ²
		8 = 18 μW/cm ² ... 180 mW/cm ²
		9 = 180 μW/cm ² ... 1,8 W/cm ²
		10 = 1,8 mW/cm ² ... 18 W/cm ²
		2 = up to UVI 30

TOCON_ABC2

Broadband SiC based UV photodetector with integrated amplifier

SPECIFICATIONS

Parameter	Symbol	Value	Unit
Spectral Characteristics			
Typical Responsivity at Peak Wavelength	S_{max}	28	mV/nW/cm ²
Wavelength of max. Spectral Responsivity	λ_{max}	280	nm
Responsivity Range ($S=0.1 \cdot S_{max}$)	–	221 ... 358	nm
Visible Blindness ($S_{max}/S_{>405nm}$)	VB	$> 10^{10}$	–
General Characteristics (T=25°C, V_{supply} =+5 V)			
Supply Voltage range	V _{Supply}	2.5 ... 5	V
Saturation Voltage	V _{Sat}	V _{Supply} - 5%	V
Typical dark output voltage at 10 MOhm load	V _{Offset}	700	µV
Typical temperature Coefficient at Peak	T _c	< ±0.3	%/K
Typical Current Consumption	I	35	µA
Bandwidth (-3 dB)	B	15	Hz
Risetime (10-90%)	t _{rise}	0.066	s
<i>(SHORTER RISE TIME AND BANDWIDTH ON REQUEST)</i>			
Maximum Ratings			
Operating Temperature	T _{opt}	-25 ... +85	°C
Storage Temperature	T _{stor}	-40 ... +100	°C
Maximum soldering temperature (for 3 seconds)	T _{sold}	300	°C

NORMALIZED SPECTRAL RESPONSIVITY

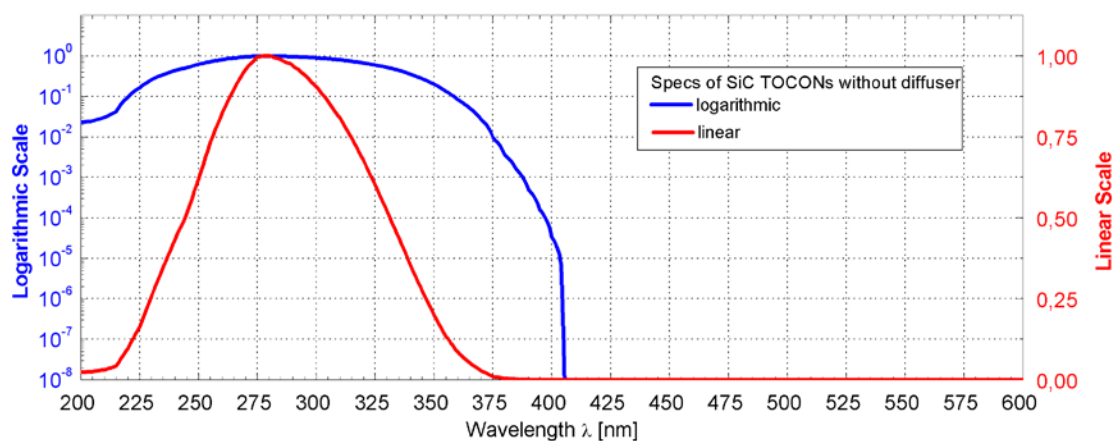

TOCON_ABC2

Broadband SiC based UV photodetector with integrated amplifier

FIELD OF VIEW

▶ 3/4

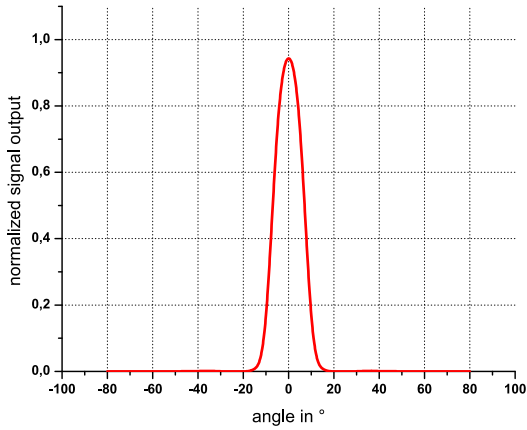

Measurement Setup:

lamp aperture diameter: 10 mm
distance lamp aperture to second aperture: 17 mm
second aperture diameter: 10 mm
distance second aperture to detector: 93 mm

pivot level = top surface of the detector window

DRAWING

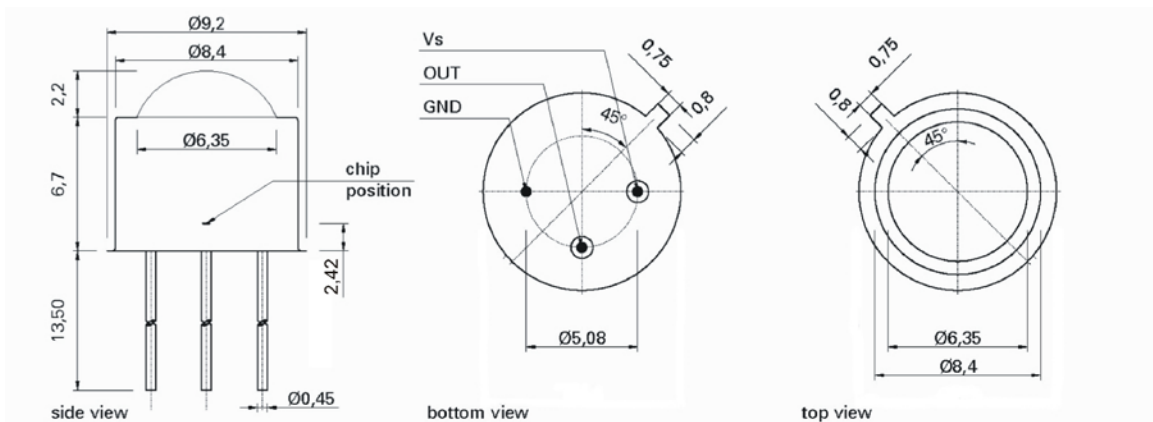

TOCON_ABC2

Broadband SiC based UV photodetector with integrated amplifier

APPLICATION NOTE FOR TOCONs

The TOCONs need a supply voltage of $V_{\text{supply}} = 2.5 \dots 5V_{\text{DC}}$ and can be directly connected to a controller or voltmeter. Please note that the theoretic maximum signal output is always a little less (approx. 5%) than the supply voltage. To learn more about perfect use of the TOCONs please refer to the TOCON FAQ list published at www.sglux.com.

CAUTION! Wrong wiring leads to destruction of the device.

For easy setup of the device please ask for a TOCON starter kit.



Miniature steel housing with M12x1 thread for the TOCON series

- Optional feature for all TOCON detectors
- Robust stainless steel M12x1 thread body, length 32 mm
- Integrated sensor connector (Binder 4-Pin plug) with 2m connector cable
- Easy to mount and to connect



Plastic probes

- Optional feature for all TOCON detectors
- UV probes in small plastic housings with a TOCON inside
- Customized housings available
- Easy to mount and to connect
- Integrated sensor connector (Binder 4-Pin plug)
- Cable available